

BROSELEY

Installation & Operating Instructions

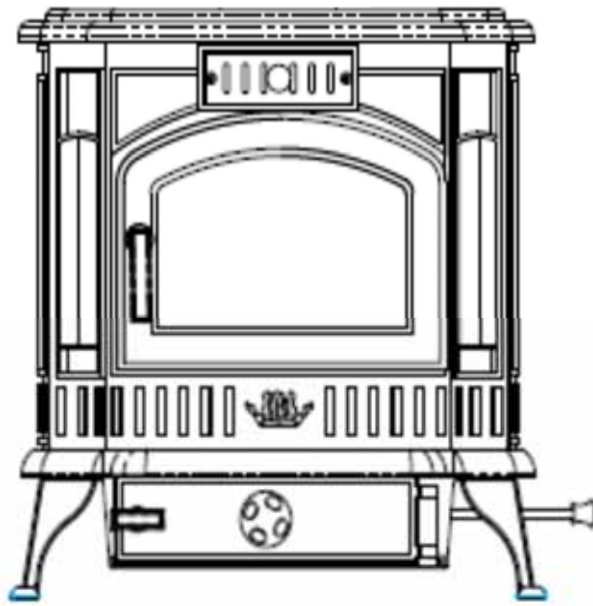

Covering Model:

Winchester,
Multifuel Stove



Tested to EN 13240



These appliances must be installed and commissioned by a HETAS registered engineer

BROSELEY

Contents

Introduction	3
Packing List	3
Health & Safety	4
Specifications	5
Dimensions	6
Hearth Requirements & Clearances	7
Chimney Requirements	8
Combustion Air Requirements	9
Assembly	10
Stove Operation	
Controls Layout	11
Controls Explained	12
Air wash System	12
Ash Pan	12
Recommended Fuels	13
Lighting the Stove	
Kindling Stage	14
Burning Wood & Burning Coal	15
Warning Notes	16
Maintenance	
Ash Removal	17
Chimney Fires	17
Chimney Sweeping	17
General Stove Cleaning	17
Glass Cleaning	17
Annual Stove Service	17
Trouble-shooting	18
Commissioning Form	19
Spare Parts	20
EC Declaration	21
Annual Service Record	22
Warranty	23

BROSELEY

Introduction

May we take this opportunity to thank you for choosing one of our cast iron, multifuel stoves.

The term multifuel refers to the fact that the appliance is capable of burning either wood logs or coal (that is suitable for closed appliances). Both of these fuels have very different air requirements in order for them to burn correctly, therefore the air controls need to be operated differently depending on the fuel being burned (see section “Stove Operation”).

See the section “Lighting the Stove” for further details. After reading this document, if there is anything you are unsure about, please contact your dealer or our Technical Support Department.

These instructions cover the basic principles to ensure the satisfactory installation of the stove, although detail may need slight modification to suit particular local site conditions. In all cases the installation must comply with current Building Regulations, Local Authority Byelaws and other specifications or regulations as they affect the installation of the stove.

It should be noted that the Building Regulations requirements may be met by adopting the relevant recommendations given in British Standards BS 8303 and BS EN 15287-1 2007 + A1 2010 as an alternative means to achieve an equivalent level of performance to that obtained following the guidance given in Approved Document J.

Please note that it is a requirement under the Broseley Fires warranty system that the installation of the stove is carried out by a Competent Person registered with a Government approved Competent Persons Scheme. HETAS Ltd operate such a Scheme and a listing of their Registered Competent Persons can be found on their website at www.hetas.co.uk.

Packing List

1x Cast-iron stove	2x Cast iron side firebricks
1x Ash Tool (poker)	1x Cast iron rear firebrick
1x Instruction booklet	1x Cast iron baffle
1x Heat Proof Gloves Set	1x Cast iron grate & Log Retainer
1x Spigot (flue collar)	1 x Steel Ash pan

All parts will be inside the main stove body upon delivery. The spigot will generally be bolted to the outside of the stove body.

BROSELEY

Health & Safety

Special care must be taken when installing the stove such that the requirements of the Health and Safety at Work Act are met.

Installation

This appliance **MUST** be installed and commissioned by a HETAS registered installer in England and Wales and a fully qualified Heating Engineer in Scotland and Ireland.

Handling

Adequate facilities must be available for loading, unloading and site handling.

Fire Cement

Some types of fire cement are caustic and should not be allowed to come into contact with the skin. In case of contact wash immediately with plenty of water.

Asbestos

This stove contains no asbestos. If there is a possibility of disturbing any asbestos in the course of installation then please seek specialist guidance and use appropriate protective equipment.

Metal Parts

When installing or servicing this stove care should be taken to avoid the possibility of personal injury.

CO Alarms

Building regulations require that whenever a new or replacement fixed solid fuel or wood/biomass appliance is installed in a dwelling an audible carbon monoxide alarm must be fitted in the same room as the appliance. Further guidance on the installation of the carbon monoxide alarm is available in BS EN 50292:2002 and from the alarm manufacturer's instructions. Provision of an alarm must not be considered a substitute for either installing the appliance correctly or ensuring regular servicing and maintenance of the appliance and chimney system.

Fire Guards

When using the stove in situations where children, aged and/or infirm persons are present a fireguard must be used to prevent accidental contact with the stove. The fireguard should be manufactured in accordance with BS 6539.

Aerosol Sprays

Do not use an aerosol spray on or near the stove when it is alight.

Operating Tool & Gloves

Always use the operating tool and glove provided when handling parts likely to be hot when the stove is in use.

BROSELEY

Specifications

In the UK these stoves have been approved by HETAS Ltd as intermittent heating appliances for burning manufactured or naturally occurring smokeless fuels and wood logs only.

Winchester MF Stove

Nominal Heat Output:	8kW
Efficiency:	80%
CO:	0.12%
Temperature of Flue Gasses:	310°C

European standards need to be complied to when installing this appliance.

BROSELEY

Dimensions

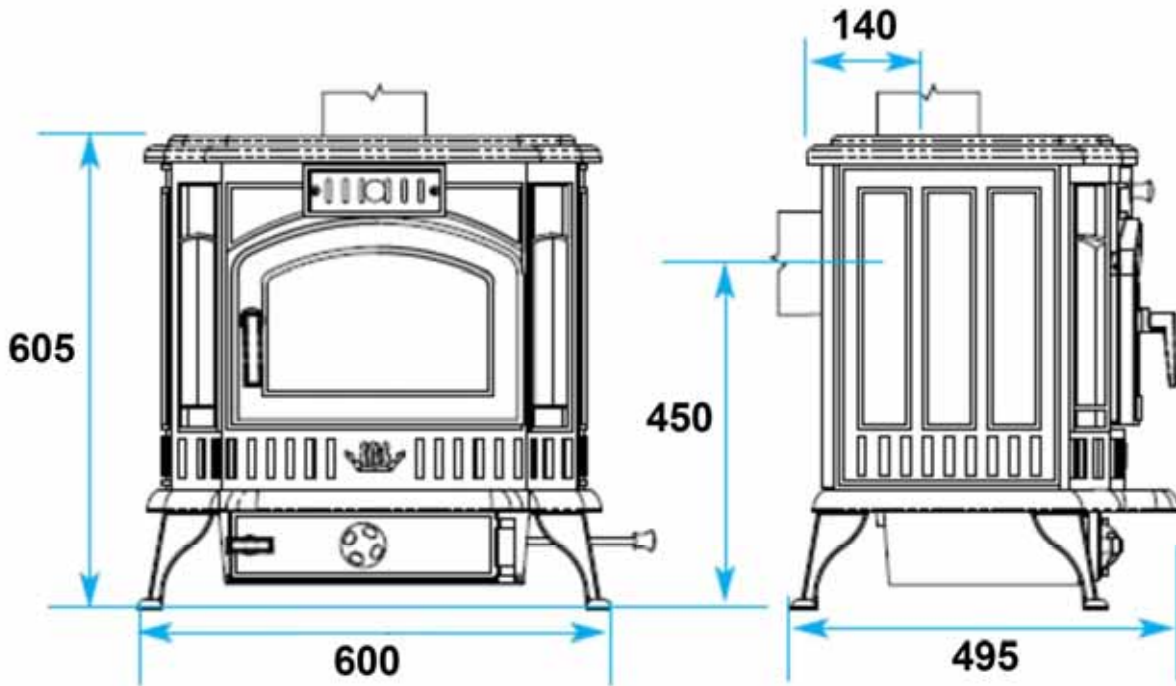

All dimensions are in millimetres

BROSELEY

Hearth Requirements & Clearances

These appliances WILL require a full constructional hearth as laid out in building regulations approved document J.

Your stove must be installed on a solid, level non-combustible hearth. The hearth protrusion in front of the stove to carpets or wooden floors must be at least 300mm. As it is possible, that on opening the door of the stove for fuel to fall out, a fender must be fitted if the hearth is flush with the carpet. These are just a few hearth specifications. Please refer to Building Regulations Approved Document J (Hearths) for more specific details.

Clearances

The stove requires the following clearances around it to ensure the heat is released into the room and to allow sufficient combustion air flow. A combustible material clearance is given to prevent damage to any items that may be affected by heat.

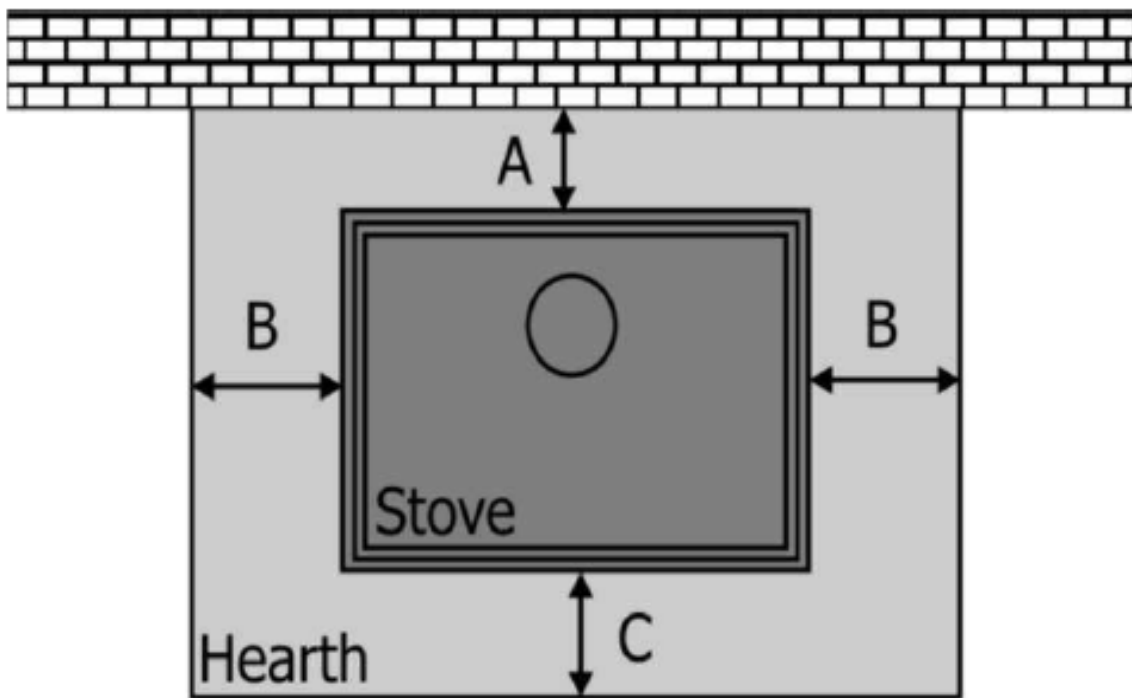

Stove Clearances	A	B	C	Above
Non-Combustible	100mm	100mm	300mm	200mm
Combustible	200mm	400mm	300mm	600mm

BROSELEY

Chimney Requirements

This appliance must not be fitted into a chimney serving another heating appliance. It is most important that there is no obstruction in the flue or chimney. Please ensure that any existing chimney is clear of obstruction and swept clean immediately before installation of the new stove. If the chimney has been used for an open fire it is recommended that it be swept for a second time having been used for a month following installation.

A flue draught minimum of 12 Pascals to a maximum 18 Pascals is required for satisfactory appliance performance. A properly built masonry or factory constructed chimney (with a minimum vertical height of 5 metres) should ensure a consistent draught (draw). 45° bends can be used in the flue run (maximum of four bends) you will need to add an extra 1 metre of vertical flue height for each bend.

The flue draught should be checked under fire at high output and if it exceeds the recommended maximum, a draught stabiliser must be fitted so that the rate of burning can be controlled, and to prevent over firing (See section "Warning Notes"). If you have any doubts about the suitability of your chimney, consult your local dealer/stockist or engineer. If your flue draft is below the minimum recommendation then it may be necessary to increase the vertical chimney height, add additional flue insulation or possibly add a special cowl to the top of the chimney (e.g. anti down draft cowl to eliminate wind induced down draft).

The outlet from the chimney should be above the roof of the building in accordance with the provisions of Building Regulations Approved Document J.

If installation is into an existing chimney then it must be sound and have no cracks or other faults which might allow fumes into the house. Older properties, especially, may have chimney faults or the cross section may be too large i.e. more than 230 mm x 230 mm. Remedial action should be taken, if required, seeking expert advice, if necessary. If it is found necessary to line the chimney then a flue liner suitable for solid fuel must be used in accordance with Building Regulations Approved Document J.

If there is no existing chimney then either a prefabricated block chimney in accordance with Building Regulations Approved Document J or a twin walled insulated stainless steel flue to BS 4543 can be used. These chimneys must be fitted in accordance with the manufacturer's instructions and Building Regulations.

If a flexible liner is required the liner diameter must not be less than 6".

Any bend in the chimney or connecting fluepipe should not exceed 45°. 90° bends are not permitted. For top flue installations it is possible to sweep through the appliance by removing the internal baffle however it is recommended that you provide adequate access (e.g. easily accessible soot door). For rear flue connection we recommend the use of a tee section, the bottom of the tee should be capped to catch soot and debris.

BROSELEY

Combustion Air Requirements

In order for the stove to perform efficiently and safely there should be an adequate air supply into the room in which the stove is installed to provide combustion air. This is particularly necessary in modern houses where drafts have been almost eliminated by double glazing etc.

Under UK building regulations any appliance over 5kW MUST have a fixed permanent air vent (see building regulations approved document J for further information).

There must not be an extractor fan fitted in the same room as the stove as this can cause the stove to emit fumes into the room. It is necessary to install a wall vent to provide the necessary combustion air and to prevent the depletion of oxygen in the room.

BROSELEY

Assembly

First ensure that all four legs are securely fastened to the base of the stove using the bolts provided.

The diagram below shows the stove with all internals taken out. To install these components follow the numbered sequence 1 to 6. To remove these internals simply reverse the sequence 6 down to 1.

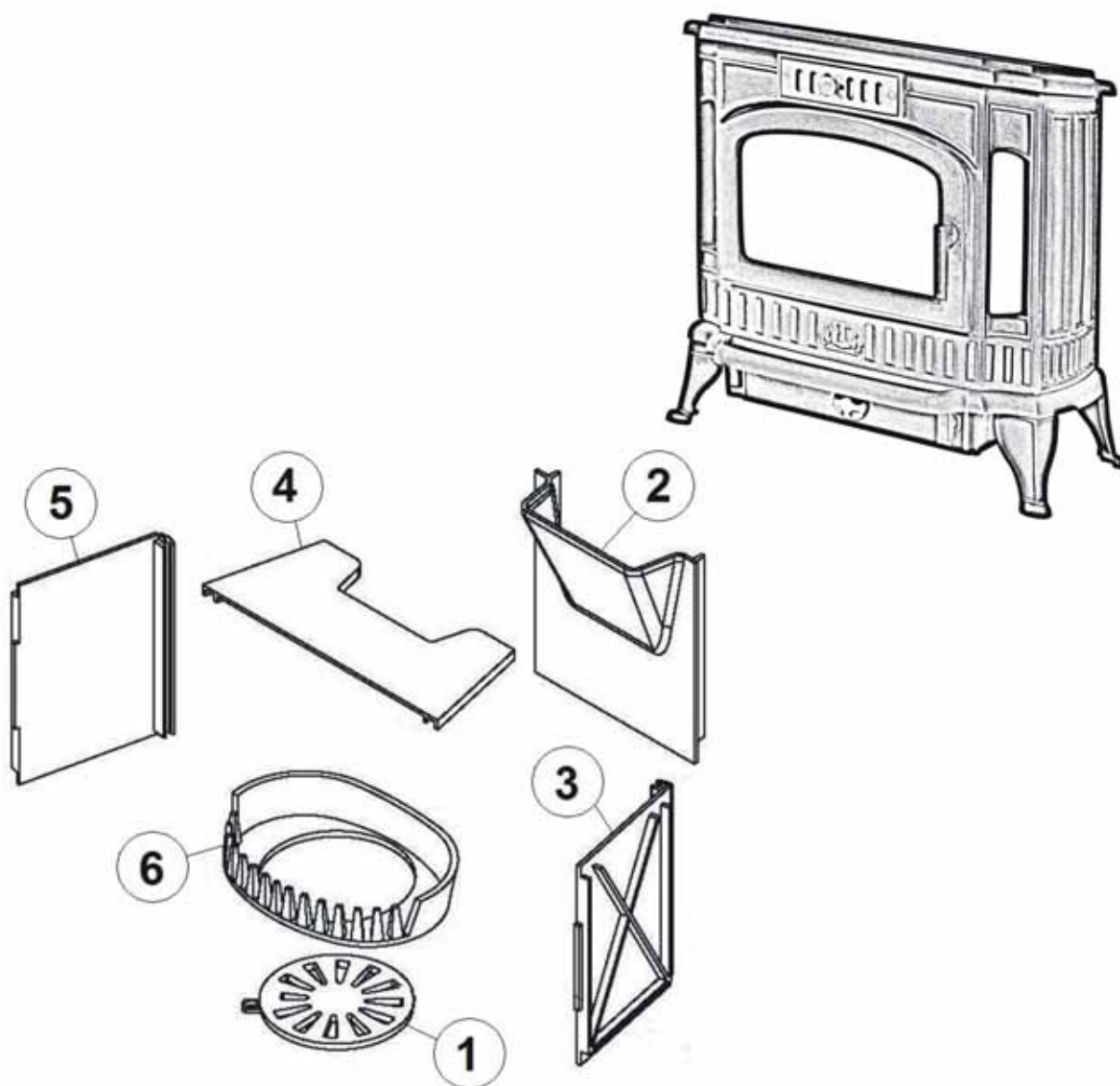

BROSELEY

Controls Layout

The stove is fitted with two air controls which need to be correctly operated in order to light and maintain a fire. Both controls are situated below the ash lip of the stove (as indicated on the diagram below) and are in the form of sliders.

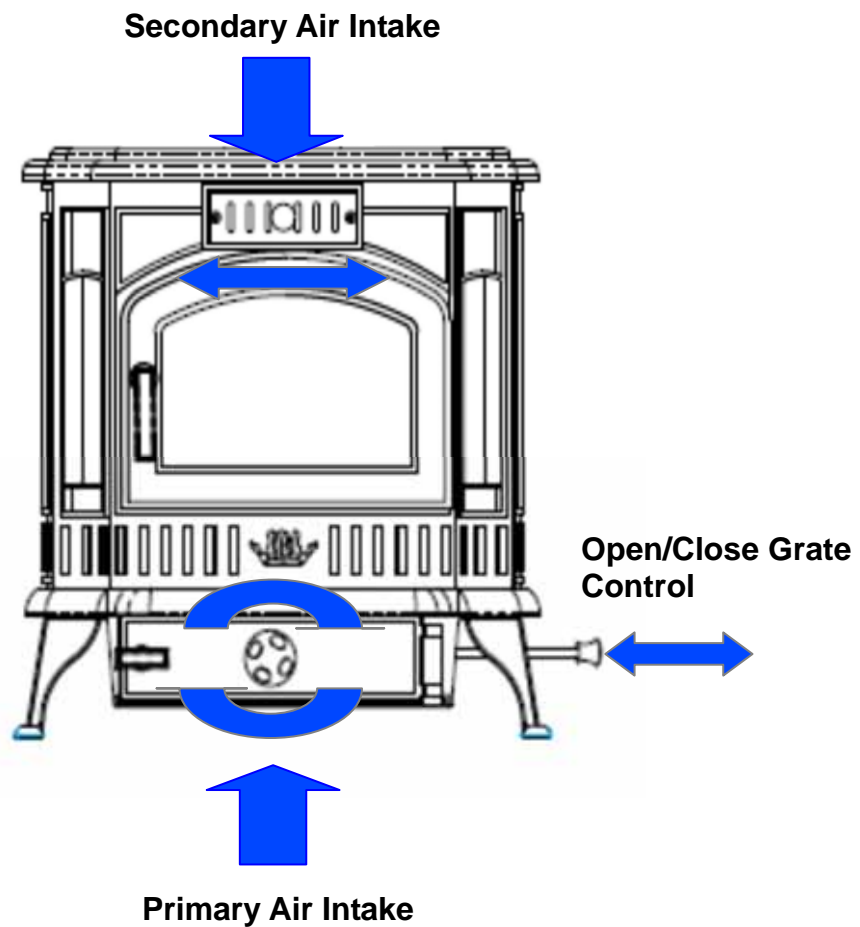

BROSELEY

Controls Explained

Primary Air Intake

The primary air intake is located below the ash lip and is in the form of a spinner. Having the spinner fully anti-clockwise indicates the intake is fully open, whilst fully clockwise means it is completely closed. The air intake is fully adjustable throughout its rotational travel to control the total amount of air required for suitable combustion.

The primary air intake is used on initial firing of the stove or when burning coal. Please see the **BURNING COAL** section for a more in depth description.

Secondary Air Intake

The secondary air intake is the top slider situated above the door. Having the slider all the way to the right indicates the air intake is fully open. Having the lever fully to the left indicates the air intake is closed. This particular air intake is adjustable fully throughout its left to right travel to control the total amount of air required for suitable combustion

This particular control is used at startup and whilst burning wood, see section **BURNING WOOD** for more information.

Open/Close Grate Control

This control is located on the right hand side of the stove and is in the form of a push/pull bar. Having the bar pulled out indicates that the grate is closed, whilst pushed in it is open. You would have the grate open when burning coal (to allow air to enter through the grate) closed would be for wood (as this creates a flat surface to burn on).

Air wash System

Air wash is a system where secondary air is drawn into the stove (by combustion) through the air intake and is deflected down the back face of the glass, thus preventing the smoke coming into contact with the glass. It does not mean that you will never have to clean the glass, but substantially lengthens the periods between having to do so. The air-wash system works best when burning dry wood. Wet wood will produce more deposits on the glass. Also, deposits will form on the back of the glass when the stove is operated on low heat for extended periods (where fuel is only just smouldering).

Ash Pan

The ash pan can be accessed by opening the ash door at the bottom of the stove (this has the primary air intake spinner on it). Using the ash tool and gloves you can hook the ash pan out where you can then pick it up using the gloves. It is recommended that you only empty the ashpan when the appliance is completely cold.

BROSELEY

Recommended Fuels

This appliance has obtained approval from HETAS Ltd., for burning –

- * HETAS approved coal suitable for a closed appliance.
- * Split Wood logs not exceeding 35cms in length and not over 20% moisture content.

Approval does not cover the use of other fuels either alone or mixed with the suitable fuels listed above.

Although approval covers the use of the smokeless fuels listed, the claimed rated output, has been obtained burning a single representative smokeless fuel, under standard test conditions. However, in the home, a variety of operating conditions can occur and the performance of the appliance may vary to some degree with these conditions and different fuels may need to be burnt at different rates to provide the same heat output.

The recommended fuels are Wood logs no longer than 35cms (dry, seasoned to under 20% moisture) and solid mineral fuels (e.g. Natural smokeless fuels) Larger coal briquettes are recommended as they concentrate less heat in one spot reducing the likelihood of damage to the grate. Ask your local fuel merchant or consult the HETAS website for more details on these fuels.

Only authorised smokeless fuels may be used in smoke control areas.

Do NOT burn “House coal” or any other coal which are intended for use on open fires. Suitable coal needs to be designed for use on closed appliances. Open fires send a large amount of heat up the chimney therefore the fuel needs to burn extremely hot in order to send heat into the room, closed appliances are highly efficient and send little heat up the chimney therefore the fuel does not need to burn as hot. Using open fire coal on a closed appliance will cause excessive wear on the stove and could result in damage which will not be covered by the products warranty.

Under NO circumstances burn “petroleum coke” or any other chemically enhanced fuel as it will burn out the internal grate and baffle plates in a very short period of time and may damage the stove beyond repair.

Do NOT burn wet wood, This will give a poor heat output and will cause heavy deposits of soot and tar to accumulate on the glass and throughout the stove and flue. The coating of soot and tar in the chimney is volatile creating a high risk of chimney fires. A growing tree contains a high percentage of water, the wood needs to be dried out (seasoned) before it is suitable for burning (this can take several years). Wood logs are best stored in a stack, sheltered from the weather, in a well ventilated area and raised off the ground. This allows the air to circulate and prevents mildew.

BROSELEY

Lighting the Stove

Curing

On initial firing you will notice a very pungent odour, this is caused through the curing of the paint, we recommend starting with short burning sessions (with smaller quantities of fuel) and build up gradually to allow the components of the stove to settle. Opening doors and windows will allow the paint curing odour to dissipate and to allow ventilation into the room. Curing times can vary but typically should take around 8-12 hours (operation at high output) to complete.

Kindling

Stage 1

Ensure the open.close grate is set correctly depending on the fuel you are burning (see section **CONTROLS EXPLAINED** if you are unsure. With the Primary and Secondary air intakes in the fully open position and the door open, start your fire using twists of newspaper (or scrunched up balls) to form a bed on the grate. Place a generous amount of dry kindling onto the newspaper, ensure there is sufficient air gaps between the kindling (a criss cross or pyramid style pattern is ideal to accomplish this).

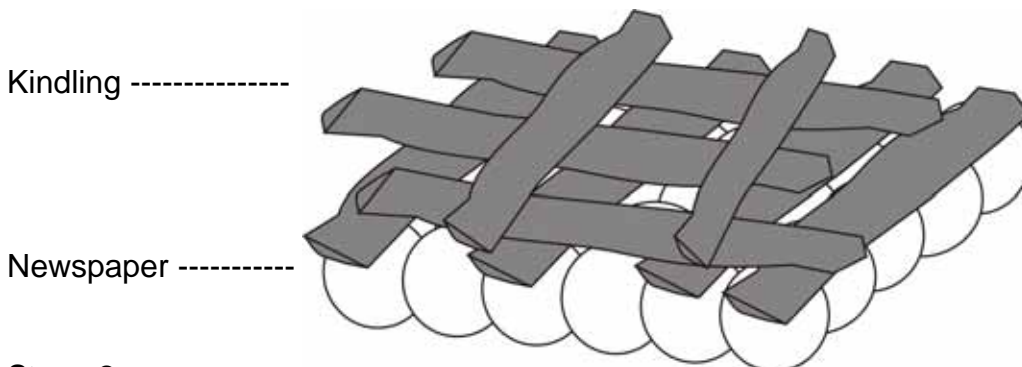

Stage 2

Ignite the paper underneath using a match or suitable fire-lighter. Allow the paper and kindling to burn until it reduces down into hot embers. If the fire is dying during this stage the door can be closed but not latched leaving a small gap for extra combustion air.

Stage 3

Add another generous load of dry kindling and allow to burn down.

It may be necessary to repeat stage 3 if the chimney is cold or if you find you have smoke entering the room. This stage is vital for getting heat into the chimney which will create the draw that takes the smoke away, we would expect this stage to take between 15-20 minutes.

It is critical that you do not leave the stove during the entire lighting and kindling stage. See Burning wood and Burning Coal sections for the next steps in starting a new fire.

BROSELEY

Burning Wood

Once you have kindled your stove (see previous page) and your chimney (flue) is sufficiently heated, you are now ready to start adding you logs.

Stage 4

Place 1-3 small logs onto the bed of hot embers using the gloves provided, close the door and reduce the Primary Air intake to approximately half way. Once the logs turn black the primary air intake can be fully closed.

Stage 5

Once the smaller logs have burned down you can now add 2-3 larger (or full size) logs and close down the Secondary Air Intake as required. You can now control the burn rate of the stove using the secondary air intake, you are looking for a controlled flame (not smouldering in the embers or licking around the lid) this is mostly visual although a flue pipe thermometer will help you determine correct control and is recommended for the initial lightings.

Stage 6

Refuel as and when required (take care to open the door gradually as flames may lick out). Open both air controls whenever refuelling , once the wood logs turn black the primary control can be closed fully and the fire controlled once again by the secondary control. If you no longer want to keep the fire going simply allow it burn out.

Burning Coal

With kindling complete you are now ready to add your approved coal.

Stage 4

Using the gloves and provided ash tool, rake the hot embers evenly over the grate and add a small amount of coal. Close the door and allow the coal to ignite then close the Secondary air intake to approximately half way. (The primary air intake should be left fully open)

Stage 5

When the small load of coal has burned down add a larger load and allow time for the coal to fully ignite. You will now control the burn rate of the stove using the Primary air intake, you are looking for a controlled flame (not smouldering in the embers or licking around the lid) this is mostly visual although a flue pipe thermometer will help you determine correct control and is recommended for the initial lightings.

Stage 6

Add coal as and when required. Ensure that you use the ash tool when refuelling coal to poke through any ash and debris so that it falls into the ash pan underneath, this is critical as coal requires a flow of air from underneath the grate.

BROSELEY

Warning Notes

Over-Firing

It is extremely important that you do NOT leave both of the air controls in the fully open position for extended periods or run the appliance with the door open. Leaving the air controls fully open (or running with the doors open) will lead to “over-firing”. Over-firing is caused when too much heat is generated within the fire chamber, this will lead to warping, buckling and general damage to the stove and its internal components. Over-firing can also be caused by an excessive flue draft.

PLEASE NOTE ANY DAMAGE TO THE APPLIANCE CAUSED THROUGH OVER-FIRING WILL NOT BE COVERED BY THE WARRANTY.

We highly recommend the use of a flue pipe thermometer so that you can monitor how much heat you are sending up the chimney, this will both enable efficient operation of your stove and also give a good indication if you are over-firing the appliance.

Fumes

Properly installed, operated and maintained, this appliance will not emit fumes into the dwelling. Occasional fumes may occur whilst de-ashing and re-fuelling. However, persistent fume emission is potentially dangerous and must not be tolerated. If fume emission does persist, the following immediate actions should be taken:-

- a) Open doors and windows to ventilate the room
- b) Let the fire go out or eject and safely dispose of fuel from the appliance
- c) Check for flue or chimney blockage and clean if required
- d) Do not attempt to relight the fire until the cause of the fume emission has been identified and corrected. If necessary seek expert advice

BROSELEY

Maintenance

Ash Removal

The ash pans can be removed by using the ash tool to hook it forward so that you can grasp the pan using the gloves provided. We would recommend emptying the ash into a metal bucket for transportation.

You should only empty the ash when the appliance and ashes are completely cool and can be disposed of in your normal household refuse.

Cleaning the Stove

We recommend only doing this when the stove is cold using a soft brush to clean any of the stove surfaces, this is normally sufficient to remove dust, ash and debris. For stubborn marks you can use a damp lint free cloth, ensure that all surfaces are dried off immediately. We do not recommend using any kind of chemicals or abrasive materials. It is possible to touch up the paint using the original metallic black stove paint, however this new paint will then need to cure.

Glass Cleaning

A damp lint free cloth is normally sufficient, however for stubborn build ups we would recommend using a very fine wire wool.

Chimney Sweeping

It is essential that your chimney (flue) is swept at least once a year by a registered professional chimney sweep. Sweeping removes particles that could otherwise fuel a chimney fire, it should also highlight any potential issues such as leaks and damage to the flue.

Chimney Fires

In the event of a chimney fire ensure both Primary and Secondary air controls are fully closed and the door(s) remain closed at all times. If the chimney fire does not go out or if there is a serious risk to people and property, call the fire brigade immediately.

Regular sweeping of the chimney will remove combustible particles and will reduce the risk of chimney fires.

Stove Servicing

Your stove should be inspected annually to ensure all seals are present and correct and to gauge the condition of the internal components. The service should be done by a HETAS registered engineer who also perform a spillage test and ascertain the correct functioning of the plumbing circuit.

BROSELEY

Trouble-shooting

Smoke comes out of the stove when the loading door is opened.

- The chimney cavity into which the 125mm flue pipe has been installed may be less than the minimum requirement.
- Deposits (soot or other obstructions) may have built up in the chimney and be restricting the flow of waste products. This flow rate is known as the 'draw'.
- Insufficient draw, this is especially common during milder weather. You will need to prolong the kindling stage to ensure the chimney (flue) is completely hot (you may even need to pre-heat the chimney using a method advised by the installer)
- Combustion air intake is not large enough or another appliance (e.g. Extractor fan) is taking air away from the stove.

The Stove does not produce the expected heat into the room.

- Has the flue pipe been sealed to the chimney to prevent heat being drawn up the chimney to waste?
- Green or wet wood is being burnt.
- The chimney has excessive draw (this is unusual). Seek installer advice with regard to installing a Flue Draught Stabiliser.
- The stove has been recessed into the existing fireplace and a lot of heat is being absorbed by the surrounding fireplace walls rather than being radiated into the room. Pull the stove forward.
- For the maximum efficiency of heat transference into the room the stove should be sited on the hearth of the fireplace rather than recessed.

The Stove burns too fast.

- Use whole logs rather than split ones.
- The wood being used may be generally too small.
- The "air-tight" seal between the fibre rope on the doors and the casting may have been lost, adjust door handle lock nuts to reinstate this seal or replace.
- The chimney has excessive draw (seek installers advice on this point).
- The fibre rope seal between the door and the glass may be leaking. Tighten or replace.
- The fibre rope on doors and glass has worn out. Replace.

BROSELEY

Commissioning Form

Commissioning Statement and Check-list

Stove Purchased From: _____

Address: _____

Telephone Inc area code: _____

Installation Date: ____/____/____ Stove Name: _____

Product Serial Number: _____ Invoice Number: _____

Stove installed by: _____

Address: _____

Telephone Inc area code: _____

HETAS Registration Number: _____

Check-list

- | | | |
|---|------------------------------|-----------------------------|
| Is the flue system the correct length and diameter for stove: | Yes <input type="checkbox"/> | No <input type="checkbox"/> |
| Flue swept and checked for soundness: | Yes <input type="checkbox"/> | No <input type="checkbox"/> |
| Manufacturers clearances adhered: | Yes <input type="checkbox"/> | No <input type="checkbox"/> |
| Smoke spillage test performed on stove: | Yes <input type="checkbox"/> | No <input type="checkbox"/> |
| Stove controls fully explained to end user: | Yes <input type="checkbox"/> | No <input type="checkbox"/> |
| Correct fuels explained to end customer: | Yes <input type="checkbox"/> | No <input type="checkbox"/> |
| CO Alarm fitted and tested: | Yes <input type="checkbox"/> | No <input type="checkbox"/> |
| Instruction booklet & HETAS certificate handed to end user: | Yes <input type="checkbox"/> | No <input type="checkbox"/> |

Signature: _____ Print Name: _____

BROSELEY

Spare Parts

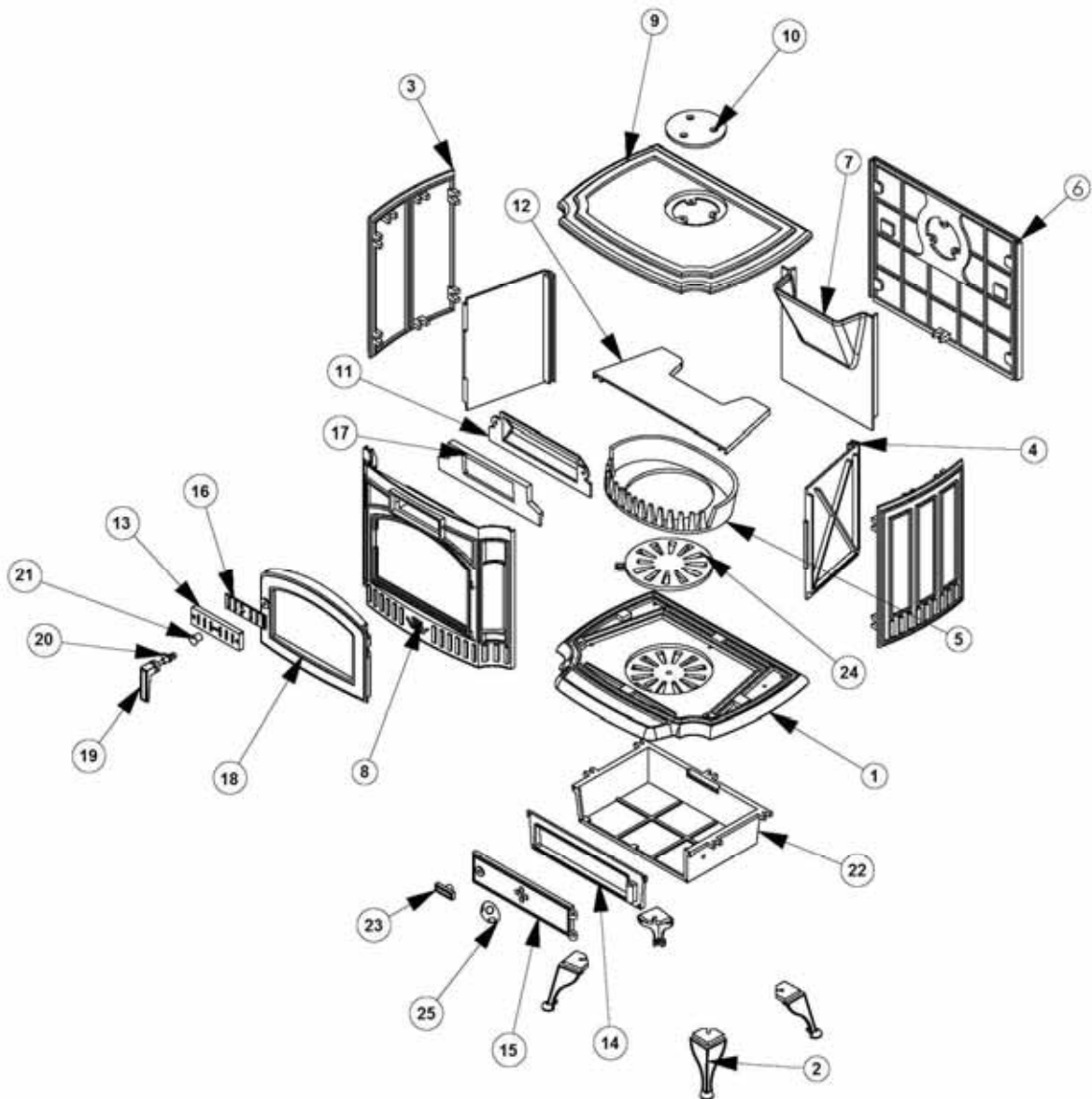

- (1) Base Casting (2) Legs (3) Side Castings (4) Side Firebricks
(5) Log Retainer (6) Rear Casting (7) Rear Firebrick (8) Front Casting (9) Lid
(10) Blanking Plate (12) Baffle (18) Door (19) Handle (24) Open/Close Grate

BROSELEY

EC Declaration



DECLARATION OF CONFORMITY

ACCORDING TO DIRECTIVES 89/106/EEC (CONSTRUCTION PRODUCTS)



ISSUED BY:

BROSELEY FIRES LTD
KNIGHTS WAY, BATTLEFIELD ENT PARK.
SHREWSBURY. SY1 3AB ph: +44 (0)1743 461444

TYPE OF EQUIPMENT:

MULTI FUEL STOVE

TRADEMARK:

BROSELEY FIRES LTD

MODEL:

Winchester

USE:

DOMESTIC SPACE HEATING

MANUFACTURER:

BROSELEY FIRES LTD
KNIGHTS WAY, BATTLEFIELD ENT PARK.
SHREWSBURY. SY1 3AB ph: +44 (0)1743 461444

NOTIFIED BODY:

RRF 1625

RRF Rhein-Ruhr Feuerstätten Prüfstelle GmbH
Firmensitz
Im Lipperfeld 34 b
D-46047 Oberhausen

The following harmonised standards and Technical specifications have been met and comply with good engineering practice and safety matters in force within the EEC

All CE standards or other documents

Initial Type Test Reports

RRF-40 07 1284

EN 13240

CE MARKING INFORMATION - See Instructions

As the Manufacturer's authorised representative established within the EEC, Broseley Fires Ltd Declare sole responsibility that the product for mentioned follows the provisions of the directives above.

13/11/2013 Shrewsbury UK
Place and date of issue

STEPHEN GOODWIN
Head of Research & Development

BROSELEY

Annual Service Record

1ST YEAR SERVICE completion date:

SERVICE ENGINEER: _____ REG. No. _____
COMPANY NAME: _____ . _____
COMPANY ADDRESS: _____ . _____

CONTACT NUMBER _____ POSTCODE: _____

2ND YEAR SERVICE completion date:

SERVICE ENGINEER: _____ . . REG. No. _____
COMPANY NAME: _____ . _____
COMPANY ADDRESS: _____ . _____

POSTCODE: _____

3RD YEAR SERVICE completion date:

SERVICE ENGINEER: _____ REG. No. _____
COMPANY NAME: _____ . _____
COMPANY ADDRESS: _____ . _____

POSTCODE: _____

4TH YEAR SERVICE completion date:

SERVICE ENGINEER: _____ REG. No. _____
COMPANY NAME: _____ . _____
COMPANY ADDRESS: _____ . _____

POSTCODE: _____

5TH YEAR SERVICE completion date:

SERVICE ENGINEER: _____ REG. No. _____
COMPANY NAME: _____ . _____
COMPANY ADDRESS: _____ . _____

POSTCODE: _____

6TH YEAR SERVICE completion date:

SERVICE ENGINEER: _____ REG. No. _____
COMPANY NAME: _____ . _____
COMPANY ADDRESS: _____ . _____

POSTCODE: _____

BROSELEY

Warranty

This appliance must be installed and commissioned by a fully qualified, registered engineer. A "Declaration of completion Certificate" must be obtained for the installation and retained by the end user. Failure to comply with these requirements may void your warranty.

You, as the end user, have a contract by law with the supplier / dealer from whom you purchased the product. That dealer then has the same contract with the manufacturer or wholesaler and these have a contract with their suppliers.

ALL CLAIMS MUST FOLLOW THIS PROCEDURE.

Thank you for choosing a Product from **Broseley Fires Ltd**. This warranty gives you specific legal rights. The statutory rights of the consumer are not affected by the warranty, or the consumers' rights against the dealer arising from their sales / purchase contract.

The manufacturers' warranty:

Your Product will be free from defective parts, material, and workmanship at the time of its original purchase for a period of Five (5) years. This Warranty will become active as of one month from the date of delivery.

This warranty does not cover any failure of the unit due to normal wear and tear, misuse, abuse, accident, illegal modification, illegal installation or repair, damage resulting from improper use or failure to maintain the product. Variations in color and texture are a natural characteristic of cast iron products. Colour changes may result from exposure to light and other elements which are a part of the aging process. These material variations and changes are not covered by this warranty. If during the warranty period, this Product fails to operate under normal use and service, due to defects in material and / or workmanship, Broseley Fires will either repair or replace the product. The repaired or replaced product shall be warranted for the remaining period of the original warranty + the time taken to days from the date of repair, whichever is longer.

Repair or replacement may involve the use of functionally equivalent reconditioned units. Replaced parts or components will become the property of Broseley Fires.

Should you wish to claim under the warranty, please contact the supplier / dealer from whom you purchased the appliance. Do not claim directly to Broseley Fires, as they are unable to process any direct claim from an end user.

Product design and any specifications are subject to change without notice. This is due to our continuous product development and improvement. The buyer will not be entitled to request free upgrades to the new design or compensation for previously purchased products or any products on order.

- This Warranty covers all Broseley Fires costs within the Warranty period.

If the appliance remains uninstalled for a period greater than six months from date of delivery the Warranty will become active six months from the date of original invoice to the distributor.

IN NO EVENT SHALL BROSELEY FIRES BE LIABLE FOR INCIDENTAL OR CONCEQUENTIAL DAMAGES OF ANY NATURE WHATSOEVER, INCLUDING BUT NOT LIMITED TO LOST PROFITS OR COMMERCIAL LOSS, TO THE FULL EXTENT THOSE DAMAGES CAN BE DISCLAIMED BY LAW. (if applicable)

NON - COVERAGE OF THE GUARANTEE

The consumable items within the product are not covered by the warranty, nor is the glass
If the end-user's claim should not be covered by this guarantee, the end-user shall be liable for costs incurred by Broseley Fires such as callout and inspection costs for examination of the product, transportation costs of the product as well as any other relevant costs.

If, after having been informed about the non-coverage of the guarantee, the end-user wants to have the repairs done, the end-user shall additionally pay for any spare parts used and for the labour and transportation costs incurred. If repairs are carried out under this guarantee, the remaining guarantee period for the product shall be extended by the period of time that has elapsed since the complaint was officially logged with Broseley Fires until the repairs have been completed

A COPY OF OUR FULL TERMS AND CONDITIONS IS AVAILABLE ON REQUEST.

** End-user means the natural or legal person who owns the product and who has not acquired it with a view to reselling or installing it in the course of business